



98-01
(Full Internal Port)
MODEL
698-01
(Reduced Internal Port)

Pressure Management Control Valve



Patent Pending

- Water Conservation
- Pipe Break Prevention
- Leakage Reduction
- System Efficiency
- Energy Savings
- Retrofits to Existing Valves
- 100% Hydraulic Control
- Supplies Optimal Pressure Based on Flow Demand
- No Inline Orifice Plate Required

The Cla-Val Model 98-01/698-01 Pressure Management Control Valve automatically adjusts downstream pressure based on demand changes in the system. This fully adjustable control valve automatically changes outlet pressure from a high setting during high flow conditions to a low setting during low flow conditions. The patent pending all-hydraulic operation design assures smooth ramping between pressure settings as flow demand conditions change. Model 98-01/698-01 easily manages the system pressure based on demand changes to reduce costly system leakage losses and line breaks.

Schematic Diagram

Item	Description
1	Hytrol (Main Valve)
2	X43 "Y" Strainer
3	X58C Restriction Assembly
4	X58A Restriction Fitting
5	X78 Stem Assembly
6	X101 Valve Position Indicator Assembly
7	CRD2S Pressure Management Control
8	CK2 (Isolation Valve)
9	X141 Gage
10	CV Flow Control (Closing)
11	CRD Pressure Reducing Control
12	Plug, Gage Connection
13	Socket, Gage Connection
14	CV Flow Control (Opening)

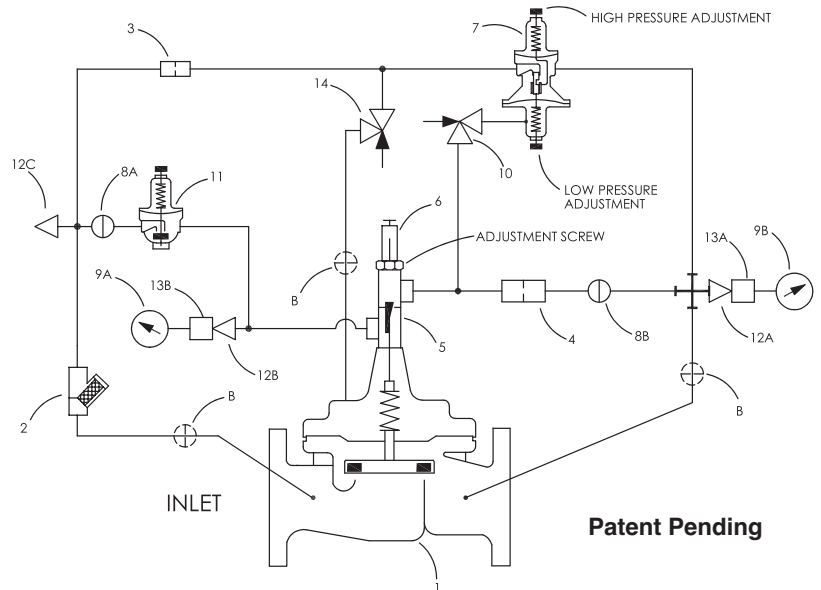

Patent Pending

Optional Features

Item	Description
B	CK2 (Isolation Valve)

Typical Performance

A desired pressure profile with reduced system pressure during low demand periods is illustrated by the solid line in chart. At low flows a minimum pressure is maintained and as flow increases delivery pressure gradually increases up to maximum pressure set point for maximum flow. The ramping is adjustable to fine tune valve to system requirements. The "water saving zone" below maximum pressure line represents valve effectiveness in reducing water losses and pipeline breakage in system.

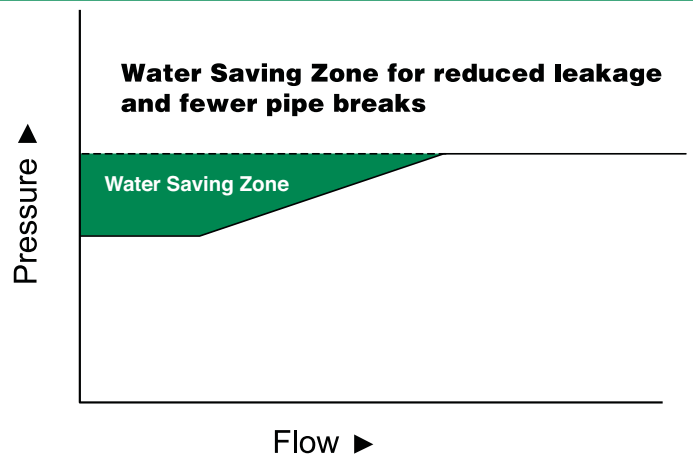

Model 98-01 (Uses Basic Valve Model 100-01)

Pressure Ratings (Recommended Maximum Pressure - psi)

Valve Body & Cover		Pressure Class			
		Flanged		Threaded	
Grade	Material	ANSI Standards*	150 lb.	300 lb.	End** Details
ASTM A536	Ductile Iron	B16.42	250	400	400
ASTM A216-WCB	Cast Steel	B16.5	285	400	400
ASTM B62	Bronze	B16.24	225	400	400

Note: * ANSI standards are for flange dimensions only.
 Flanged valves are available faced but not drilled.
 ** End Details machined to ANSI B2.1 specifications.

Materials

Component	Standard Material Combinations		
Body & Cover	Ductile Iron	Cast Steel	Bronze
Available Sizes	2" - 16"	2" - 16"	2" - 16"
Disc Retainer & Diaphragm Washer	Cast Iron	Cast Steel	Bronze
Trim: Disc Guide, Seat & Cover Bearing	Bronze is Standard Stainless Steel is Optional		
Disc	Buna-N® Rubber		
Diaphragm	Nylon Reinforced Buna-N® Rubber		
Stem, Nut & Spring	Stainless Steel		

For material options not listed, consult factory.
 Cla-Val manufactures valves in more than 50 different alloys.

Dimensions (In inches)

100-01 (Globe)

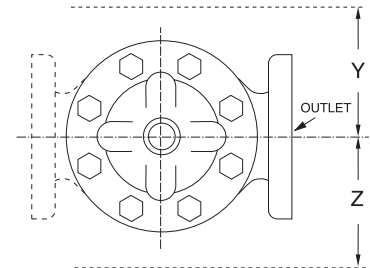
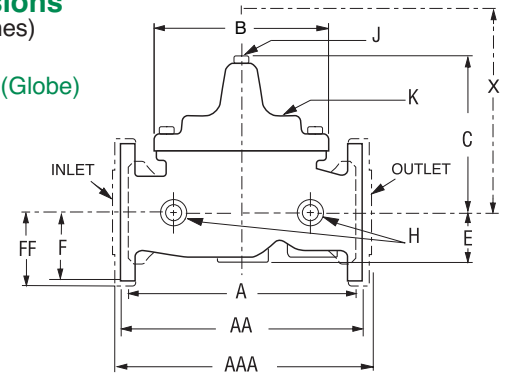

100-01 (Angle)

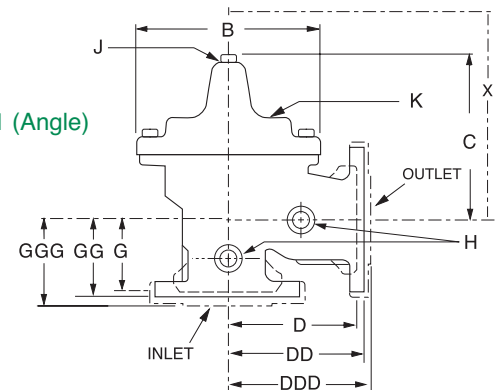

Model 98-01 Dimensions (In Inches)

Valve Size (Inches)	2	3	4	6	8	10	12	16
A Threaded	9.38	12.50	—	—	—	—	—	—
AA 150 ANSI	9.38	12.00	15.00	20.00	25.38	29.75	34.00	41.38
AAA 300 ANSI	10.00	13.25	15.62	21.00	26.38	31.12	35.50	43.50
B Dia.	6.62	9.12	11.50	15.75	20.00	23.62	28.00	35.50
C Max.	6.50	8.19	20.12	23.25	27.12	17.12	20.88	25.00
D Threaded	4.75	6.25	—	—	—	—	—	—
DD 150 ANSI	4.75	6.00	7.50	10.00	12.75	14.88	17.00	20.81
DDD 300 ANSI	5.00	6.38	7.88	10.50	13.25	15.56	17.75	21.62
E	1.50	2.06	3.19	4.31	5.31	9.25	10.75	15.50
F 150 ANSI	3.00	3.75	4.50	5.50	6.75	8.00	9.50	11.75
FF 300 ANSI	3.25	4.13	5.00	6.25	7.50	8.75	10.25	12.75
G Threaded	3.25	4.50	—	—	—	—	—	—
GG 150 ANSI	3.25	4.00	5.00	6.00	8.00	8.62	13.75	15.69
GGG 300 ANSI	3.50	4.38	5.31	6.50	8.50	9.31	14.50	16.50
H NPT Body Tapping	3/8	1/2	3/4	3/4	1	1	1	1
J NPT Cover Center Plug	1/2	1/2	3/4	3/4	1	1	1 1/4	2
K NPT Cover Tapping	3/8	1/2	3/4	3/4	1	1	1	1
Valve Stem Internal Thread UNF	10-32	1/4-28	1/4-28	3/8-24	3/8-24	3/8-24	3/8-24	1/2-20
Stem Travel	0.6	0.8	1.1	1.7	2.3	2.8	3.4	4.5
Approx. Ship Wt. Lbs.	35	70	140	285	500	780	1165	2265
X Pilot System	15.00	15.00	32.00	35.00	31.00	33.00	36.00	40.00
Y Pilot System	13.00	13.00	20.00	22.00	24.00	26.00	28.00	32.00
Z Pilot System	13.00	13.00	21.00	22.00	24.00	26.00	28.00	32.00

Model 698-01 (Uses Basic Valve Model 100-20)

Dimensions (In inches)

Pressure Ratings (Recommended Maximum Pressure - psi)

Valve Body & Cover		Pressure Class		
		Flanged		
Grade	Material	ANSI Standards*	150 lb.	300 lb.
ASTM A536	Ductile Iron	B16.42	250	400
ASTM A216-WCB	Cast Steel	B16.5	285	400
ASTM B62	Bronze	B16.24	225	400

Note: *ANSI standards are for flange dimensions only.
Flanged valves are available faced but not drilled.

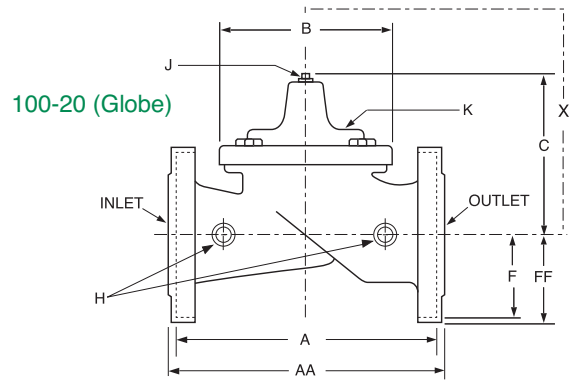

Materials





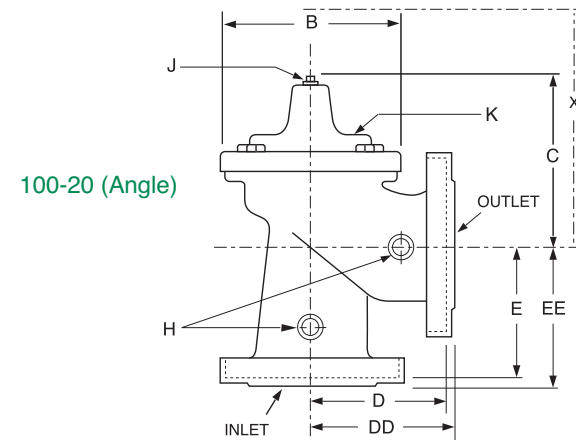
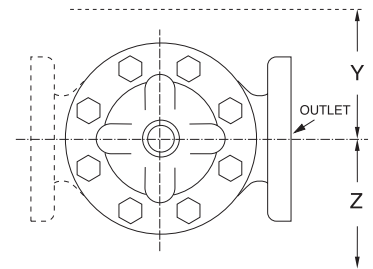



























Component	Standard Material Combinations		
Body & Cover	Ductile Iron	Cast Steel	Bronze
Available Sizes	3" - 24"	3" - 16"	3" - 16"
Disc Retainer & Diaphragm Washer	Cast Iron	Cast Steel	Bronze
Trim: Disc Guide, Seat & Cover Bearing	Bronze is Standard Stainless Steel is Optional		
Disc	Buna-N® Rubber		
Diaphragm	Nylon Reinforced Buna-N® Rubber		
Stem, Nut & Spring	Stainless Steel		

For material options not listed, consult factory.
Cla-Val manufactures valves in more than 50 different alloys.



Model 698-01 Dimensions (In Inches)

Valve Size (Inches)	3	4	6	8	10	12	14	16	18	20	24
A 150 ANSI	10.25	13.88	17.75	21.38	26.00	30.00	34.25	35.00	42.12	48.00	48.00
AA 300 ANSI	11.00	14.50	18.62	22.38	27.38	31.50	—	36.62	43.63	49.62	49.75
B Dia.	6.62	9.12	11.50	15.75	20.00	23.62	28.00	28.00	35.44	35.44	35.44
C Max.	7.00	8.62	21.75	26.12	29.00	21.00	20.88	25.75	25.00	31.00	31.00
D 150 ANSI	—	6.94	8.88	10.69	—	—	—	—	—	—	—
DD 300 ANSI	—	7.25	9.38	11.19	—	—	—	—	—	—	—
E 150 ANSI	—	5.50	6.75	7.25	—	—	—	—	—	—	—
EE 300 ANSI	—	5.81	7.25	7.75	—	—	—	—	—	—	—
F 150 ANSI	3.75	4.50	5.50	6.75	8.00	9.50	11.00	11.75	15.88	14.56	17.00
FF 300 ANSI	4.12	5.00	6.25	7.50	8.75	10.25	—	12.75	15.88	16.06	19.00
H NPT Body Tapping	3/8	1/2	3/4	3/4	1	1	1	1	1	1	1
J NPT Cover Center Plug	1/2	1/2	3/4	3/4	1	1	1 1/4	1 1/4	2	2	2
K NPT Cover Tapping	3/8	1/2	3/4	3/4	1	1	1	1	1	1	1
Valve Stem Internal Thread UNF	10-32	1/4-28	1/4-28	3/8-24	3/8-24	3/8-24	3/8-24	3/8-24	1/2-20	1/2-20	1/2-20
Stem Travel	0.6	0.8	1.1	1.7	2.3	2.8	3.4	3.4	3.4	4.5	4.5
Approx. Ship Wt. Lbs.	45	85	195	330	625	900	1250	1380	1500	2551	2733
X Pilot System	15.00	15.00	34.00	38.00	41.00	36.00	36.00	41.00	40.00	46.00	55.00
Y Pilot System	11.00	11.00	20.00	22.00	24.00	24.00	26.00	26.00	30.00	30.00	30.00
Z Pilot System	11.00	11.00	21.00	22.00	24.00	24.00	26.00	26.00	30.00	30.00	30.00

Valve Selection		These Symbols  and  Indicate Available Sizes												
		Inches	2	3	4	6	8	10	12	16	18	20	24	
		mm	50	80	100	150	200	250	300	400	450	500	600	
		End Detail	Threaded & Flanged			Flanged								
Model 98-01	Basic Valve 100-01	Globe												
		Angle												
	Suggested Flow (gpm)	Max. Continuous	210	460	800	1800	3100	4900	7000	11000				
		Max. Intermittent	260	580	990	2250	3900	6150	8720	13700				
	Consult Factory for Minimum Flows													
	Suggested Flow (Liters/Sec)	Max. Continuous	13	29	50	113	195	309	441	693				
		Max. Intermittent	16	37	62	142	246	387	549	863				
Consult Factory for Minimum Flows														
For Larger Sizes Consult Factory														
Model 698-01	Basic Valve 100-20	Globe												
		Angle												
	Suggested Flow (gpm)	Max. Continuous		260	580	1025	2300	4100	6400	9230	16500	16500	16500	
		Consult Factory for Minimum Flows												
	Suggested Flow (Liters/Sec)	Max. Continuous		16	37	65	145	258	403	581	1040	1040	1040	
Consult Factory for Minimum Flows														

698-01 is the reduced internal port size version of the 98-01.

For 100-01 basic valves, suggested flow calculations were based on flow through Schedule 40 Pipe. Maximum continuous flow is approx. 20 ft/sec (6.1 meters/sec) and maximum intermittent is approx. 25 ft/sec (7.6 meters/sec) and minimum continuous flow is approx. 1 ft/sec (.3 meters/sec). For 100-20 basic valves, suggested flow calculations were based on flow through the valve seat. Approx. 26 ft/sec (7.9 meters/sec) was used for maximum continuous flow and 1 ft/sec (.3 meters/sec) is used for minimum continuous flow.

Many factors should be considered in sizing pressure reducing valves including inlet pressure, outlet pressure and flow rates. For sizing questions or cavitation analysis, consult Cla-Val with system details.

Not Recommended for Dead-end Service

Pilot System Specifications

Outlet Pressure Adjustment Range: **Materials**

High Flow Pressure Setting:
100 psi (6.9 bar) Maximum

Low Flow Pressure Setting:
Up to 25 psi (1.7 bar) below high setting

Temperature Range
Water: to 180°F

Standard Pilot System Materials

Pilot Control: Bronze ASTM B62
Trim: Stainless Steel Type 303
Rubber: Buna-N® Synthetic Rubber

Optional Pilot System Materials

Pilot Systems are available with optional Aluminum, Stainless Steel or Monel materials at additional cost.

When Ordering, Please Specify

1. Catalog No. 98-01 or No. 698-01
2. Valve Size
3. Pattern - Globe or Angle
4. Pressure Class
5. Threaded or Flanged
6. Trim Material
7. Desired Options
8. When Vertically Installed



CLA-VAL™

E-98-01/698-01

CLA-VAL

PO Box 1325 Newport Beach CA 92659-0325
Phone: 949-722-4800 • Fax: 949-548-5441

CLA-VAL CANADA

4687 Christie Drive
Beamsville, Ontario
Canada LOR 1B4
Phone: 905-563-4963
Fax: 905-563-4040

CLA-VAL EUROPE

Chemin des Mesanges 1
CH-1032 Romanel/
Lausanne, Switzerland
Phone: 41-21-643-15-55
Fax: 41-21-643-15-50

©COPYRIGHT CLA-VAL 2008 Printed in USA
Specifications subject to change without notice.

www.cla-val.com

Represented By:



HARPER INTERNATIONAL

800.551.2733 F 203.323.7100
www.SolutionsByHarper.com